

POWER-GEN EUROPE 2007

MADRID, SPAIN

JUNE 26 – 28, 2007

**REDUCING 1.5 MILLION TONNES OF CO<sub>2</sub> ANNUALLY IN EUROPE:**

**Achieving Important Improvements with Little Investment**

**Compostilla Power Plant – Case Study**



## ABSTRACT

Energy efficiency is crucial in meeting the unprecedented energy and environmental challenges faced by Europe in the coming decades. Energy efficiency improvements in Europe could lead to a reduction in the direct cost of energy consumption of more than €100 billion annually by 2020. Efficiency improvements will also lead to the reduction of over 780 millions tonnes of CO<sub>2</sub> annually in the EU. Among the many potential methods for reducing losses and improving generating efficiency among the generating assets of the EU, there is a small measure that can lead to significant results: The reduction of windage friction losses within a generator by increasing the hydrogen purity and improving hydrogen pressure stability can lead to the reduction of more than 1.5 million tonnes of CO<sub>2</sub> yearly. This estimation is based on an average improvement of 3,000 MWh/year for each of the greater than 500 hydrogen cooled coal fired steam generators located throughout Europe.

Windage loss, accounting for 30-40% of generator losses in hydrogen-cooled generators, is caused by fluid friction between the hydrogen gas, enclosed in the generator for cooling purposes, and the rotor. This loss increases as the purity of the gas decreases. The purity of the hydrogen gas has traditionally been maintained by feeding high-purity hydrogen into the generator from a high-pressure hydrogen gas cylinder, tube trailers, or liquid tanks. However, these methods can only maintain the purity level at 96-98% at best /2/.

ENDESA Generación, S.A., together with Proton Energy Systems, Inc. and BESEL, S.A., have carried out a project at ENDESA's Compostilla Power Plant whose aim was to increase and maintain the purity of hydrogen gas above 99% and therefore, improving generator efficiency, capacity, and longevity, by installing a HOGENTM onsite hydrogen generation system and an innovative StableFlowTM hydrogen control system that controls the quality of the hydrogen cooling gas within the generator casing. The evaluation was conducted as part of a Research and Development project named EFIALTER: FIT-120000-2006-73, funded by the Spanish Department of Industry, Commerce and Tourism in the frame of the Research and Development PROFIT Program.

Evaluation of the systems was conducted on Compostilla's generator group# 3, a 330 MW steam turbine generator. The evaluation confirmed that the equipment enhanced hydrogen purity in the generator from 97.5% to greater than 99%, thereby reducing windage loss by 3,000 MWh/year at 6,000 hours of operation.

## INTRODUCTION

The high thermal conductivity of hydrogen remains a key advantage in its use as a cooling fluid in electric power generators. The density of hydrogen is also an advantage over that of air. Since hydrogen's density is one-fourteenth the density of air at a given temperature and pressure, the use of hydrogen reduces the windage friction losses within a generator to a small fraction of the losses encountered when the generator is cooled by air /3/.

Windage loss, accounting for 30-40% of generator losses in hydrogen-cooled generators, is caused by fluid friction between the gas, enclosed in the generator for cooling purposes, and the rotor. This loss increases as the purity of the gas decreases. The purity of the hydrogen gas has traditionally been maintained by feeding high-purity hydrogen into the generator from a high-pressure hydrogen gas cylinder, tube trailers, or liquid tanks. However, these methods can only maintain the purity level at 96-98% at best /2/.

Critical to the proper implementation of hydrogen cooling gas at a power plant is the supply of a continuous stable flow of high purity hydrogen from a trusted source. The list of traditional sources of hydrogen includes delivered cylinders, tube trailers, and liquid tanks. Historically, the alternative — onsite hydrogen generation systems — have been deployed to very remote, hard to reach locations around the globe. In recent years however, onsite hydrogen generation systems have been adopted by an increasing number of power plants as an alternative supply method for a variety of reasons. One such Endesa power plant made the decision to go with onsite hydrogen generation in 2006. Endesa's Compostilla power plant located in Cubillos del Sil (Ponferrada, León), Spain made the move toward hydrogen independence by installing an onsite hydrogen generation system to supply their daily hydrogen makeup requirements. Compostilla plant operators made their decision to go with onsite generation based on just a few key reasons, but have realized that there are considerable benefits that go well beyond simply supplying their daily makeup gas. Plant operators have also installed an innovative product that controls

the quality of the hydrogen cooling gas within the generator casing, which has resulted in improved generator efficiency, capacity, and longevity.

## BACKGROUND

As a major step toward meeting the unprecedented energy challenges facing the EU, the European Commission presented on the 19<sup>th</sup> October 2006 its Energy Efficiency Action Plan. The Plan contains a package of priority measures covering a wide range of cost-effective energy efficiency initiatives. These include actions to make energy appliances, buildings, transportation and energy generation more efficient. Stringent new energy efficiency standards, promotion of energy services, specific financing mechanisms to support more energy efficient products are proposed /4/.

The Plan emphasises the considerable potential for reducing losses in the generation, transmission and distribution of electricity. The Action Plan proposes targeted instruments to improve the efficiency of both new and existing generation capacity and to reduce transmission and distribution losses /4/.

"Europeans need to save energy. Europe wastes at least 20% of the energy it produces. By saving energy, Europe will help address climate change, as well as its rising consumption, and its dependence on fossil fuels imported from outside the Union's borders." said Energy Commissioner Piebalgs. "Energy efficiency is crucial for Europe: If we take action now, the direct cost of our energy consumption could be reduced by more than €100 billion annually by 2020; around 780 millions tonnes of CO<sub>2</sub> will also be avoided yearly" he pointed out /4/.

The Commission will furthermore propose an international agreement on energy efficiency. Altogether, over 75 measures are set forth /4/.

Among the considerable potential for reducing losses in the generation and improving the efficiency of existing generation capacity, **there is a small measure that can lead to important results: Reducing windage friction losses within a generator improving the hydrogen purity and reducing hydrogen pressure instability.**

### Hydrogen gas purity

The purity of hydrogen within a generator casing is important for several reasons.

**First** and foremost is **safety**. An explosive atmosphere exists when the hydrogen over air concentration in a generator falls below 75%. The primary function of purity monitoring systems has been to avoid this disastrous condition. Most plants will initiate a shutdown and automatic CO<sub>2</sub> purge of the generator if the concentration falls below 85% /3/.

**Secondarily**, hydrogen's purity within a generator correlates directly with windage friction losses associated with an increase in hydrogen gas density. As windage friction losses increase due to impurities, the financial loss to the power plant correspondingly increases. While the small percentage decrease in purity within the generator casing may not present a safety concern the impact on the plant's bottom line is dramatic. The manual periodic gas purge employed at the Power Plants can cause the generators to **operate much less efficiently than designed and directly affected fuel consumption and emissions** /3/.

#### **Hydrogen Gas Pressure instability**

Hydrogen gas pressure within the generator casing can vary due to the "batch" method of maintaining hydrogen pressure employed at Power Plants /3/.

Maintaining a stable hydrogen pressure at the OEM specified level is critical to the ability of the hydrogen coolant gas to effectively remove heat from the generator. At increased pressures, hydrogen becomes denser, improving its capacity to absorb and remove heat. As a result, additional load may be carried with no increase in the temperature rise of the windings /3/.

Increasing hydrogen pressure also permits operation at normal load with the temperature of the water supplied to the gas cooler in excess of normal /3/.

This increase in kilovolt-amperes due to maintaining a constant hydrogen pressure at the OEM's specifications translates directly to a plant's ability to operate at maximum electric power capacity. The ability to operate at maximum electric power capacity during peak demand

periods can allow plants to sell all available power when electricity prices are at their highest, increasing the revenue to the plant /3/.

ENDESA Generación, S.A., together with Proton Energy Systems, Inc. and BESEL, S.A., have carried out a project at ENDESA's Compostilla Power Plant whose aim was to increase and maintain the purity of hydrogen gas above 99% and therefore, improving generator efficiency, capacity, and longevity, by installing a HOGENTM onsite hydrogen generation system and an innovative StableFlowTM hydrogen control system that controls the quality of the hydrogen cooling gas within the generator casing.

#### **AIMS OF THE PROJECT**

Like any critical resource required by the plant to produce electric power, the supply and use of hydrogen gas should not be taken lightly. Considerations need to be made to control costs, secure a reliable supply, insure the safety of the installation, and implement the most efficient way of operating the generator hydrogen system. Critical to the proper implementation of such a system is the supply of a continuous stable flow of high purity hydrogen from a trusted source.

The main objective of the EFIALTER: FIT-120000-2006-73 project is to increase the Compostilla power plant efficiency through the optimization of the generator hydrogen gas cooling system.

In order to achieve this main objective, the influence of the hydrogen purity and pressure stability on the generator efficiency under actual performance conditions will be assessed.

Partial aims of the project are the following:

- a) Improving hydrogen gas purity:
- b) Improving hydrogen gas pressure instability
- c) Development of two methods to measure the losses and efficiency of the generator: direct measurements and calculations, in order to assess the improvements achieved.

**PHYSICS BEHIND THE SOLUTION**

**Effects of Cooling Gas Quality**

The quality of the hydrogen cooling gas has an impact on the overall operation of an electric power generator in three principal ways /3/.

- Hydrogen purity directly affects the operating efficiency of the generator.
- Hydrogen's moisture content affects the longevity of the generator's internal components.
- The stability of the hydrogen gas pressure within the generator affects the maximum generating capacity of the electric power generator.

The density of the hydrogen gas within the generator casing has a physical affect on the windage loss of the generator and the thermal conductivity of the gas and its ability to remove heat /3/.

**Gas Density versus Windage Losses**

Air is the most likely impurity to affect hydrogen density within the generator casing. Air is 14.4 times as dense as hydrogen, so even relatively low levels of air increase the density of the hydrogen-air mixture considerably /3/.

This is shown as:

$$G_{dens} = (H_{pur} \times 1) + (A_{bal} \times 14.4)$$

Where:

$G_{dens}$  = Increase in Gas Density (%)

$H_{pur}$  = Purity of Hydrogen in Generator Casing (%)

$A_{bal}$  = Balance of Impurity (air) in Generator Casing (%)

Example:

Hydrogen with a purity level of 97.0% and the balance of impurity being air at 3% will have the following affect on gas density.

$$[(0.97 \times 1) + (0.03 \times 14.4)] \times 100 = 140.2 \% \text{ change}$$

The relationship between hydrogen gas purity and gas density is illustrated in the chart below /3/.

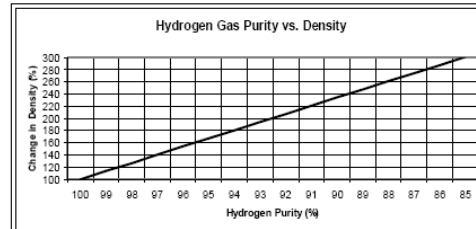

Figure 1- Relationship between hydrogen gas purity and gas density

The change in gas density will have a negative affect on the windage loss of the generator. Windage losses are typically stated at nominal pressure above atmospheric pressure and at some nominal purity. The losses can be adjusted for actual operating conditions by some simple calculations /3/.

This is shown as:

$$G_{loss} = G_{wind} \times (D_{act} / D_{base}) \times (P_{act} + 14.7) / (P_{spec} + 14.7)$$

Where:

$G_{loss}$  = Total Generator Electrical Losses due to Windage (kW)

$G_{wind}$  = Baseline Generator Windage Loss (kW)

$D_{act}$  = Actual Gas Density due to Impurities (%)

$D_{base}$  = Gas Density Baseline (%)

$P_{act}$  = Actual Generator Operating Pressure (psig)

$P_{spec}$  = Generator Operating Pressure Specification (psig)

Example:

A generator has an OEM specified windage loss of 1000 kW at 98.5% purity and a rated operating pressure of 60 psig. If the actual site conditions are 92% hydrogen gas purity and a 57.5 psig actual operating pressure the generator windage loss would be:

$$G_{loss} = 1000 \times (210/120) \times (57.5 + 14.7) / (60 + 14.7) = 1691$$

The OEM specified baseline windage loss is subtracted from the total to get the net windage loss associated with hydrogen gas purity.

$$G_{\text{net}} = 1691 - 1000 = 691 \text{ kW}$$

$G_{\text{net}}$  = Net windage loss associated with hydrogen purity (kW)

So, an additional 691 kW is lost due to operating the generator with a hydrogen gas purity of 92% /3/.

### Gas Density versus Heat Removal

The improvement in the thermal capability of the generator is proportional to the square root of the absolute pressure increase in the generator casing /3/.

This is shown as:

$$G_{\text{cap}} = \sqrt{\left( \frac{P_{\text{spec}} + 14.965}{P_{\text{low}} + 14.965} \right)} - 1$$

Where:

$G_{\text{cap}}$  = Increase in Generator Capacity (%)

$P_{\text{low}}$  = Pressure below OEM Max Specification

$P_{\text{spec}}$  = Pressure at OEM Max Specification

Example:

An increase in H<sub>2</sub> pressure of 2 psi (from 28 psig to 30 psig) would increase generator capacity capability by 2.3%.

The increased capacity is due to better heat removal from the copper windings associated with the higher density of the hydrogen gas. The higher density also has a small effect on the windage loss of the generator, but this is minimal in comparison to the gain in overall generating capacity /3/.

### PROCEDURE TO MEASURE GENERATOR EFFICIENCY

Generator efficiency is obtained by the difference between mechanical power measured at the shaft of the generator and electrical power delivered by the generator. Both measurements have to be precise.

The project implements a torque meter based on a wireless telemetric system coupled around the generator shaft in order to get a precise torque measure, and in addition a reliable inlet power measure in the generator. This innovative application of an existent technology will let us know the generator efficiency with a high grade of accuracy.

### Torque Measurement system

In order to obtain a reliable and accurate generator efficiency value; a reliable and accurate measurement system is needed.

An innovative torque measurement system with a high grade of accuracy was designed and installed in a Compostilla Power plant generator shaft.

The design of the torque measurement system is mainly based on a strain gage system coupled to a telemetric one, designed to send and receive the output signal and electric power.

The general principle of a strain gage torque meter system performance is the following:

- 1) Getting electrical operating power from an outside source to the coupling.
- 2) Feeding that power through a four arm strain gage bridge located on the rotating coupling.
- 3) Transmitting the resulting signal from the coupling back to a stationary receiver.

The strain gages have to be directly affixed to a thinned down area on the coupling spacer (centre spool piece). As torque is applied, the twisting localized in the area of the strain gages creates a signal by the unbalancing of the strain gage bridge. Since the coupling spacer will be exposed to axial, centrifugal, and misalignment loads in addition to torque, the strain gages of the Wheatstone bridge changes its electric output signal. The output of the rotating strain gage circuit is amplified and transmitted back to the stationary component by an FM (frequency modulated) signal.

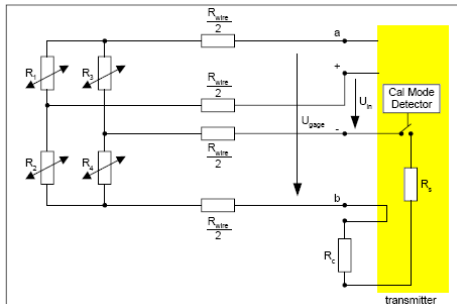

Figure 1- Wheatstone bridge

The system installed in Compostilla is compound by the following elements:

1. **Rotating coil:** An aluminium alloy coil is wound around the shaft and carries the Wheatstone signal amplifier which receives the output gage signal and sends it to the stationary receiver. It also sends the power supply to the gages through an induction based system is wound around the coil.
2. **Stationary receiver and telemetry receiver:** These two devices receive the output signal and transform it into a 0-10 V signal. It also sends the power to the Wheatstone bridge.
3. **Gages:** The system is compound by four gages which modify their resistance when a torque is applied to the shaft. This resistance variation creates a Wheatstone bridge output voltage change that is translated in the telemetry receiver in a respective output voltage signal.

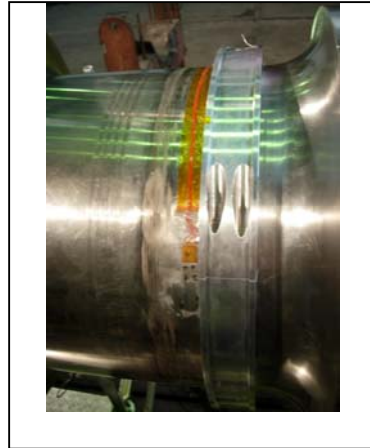

Image 1- Rotating coil and 2 strain gages installed



Image 2- Stationary receiver mounted



Image 3- Telemetry receiver installed into a box

With this system installed in the Compostilla Power Plant, small torque change rates - produced by changing hydrogen purity and stabilising hydrogen pressure to be fed to the generator - can be measured.

**Monitoring protocol**

The monitoring protocol must consider that we are testing both hydrogen feeding systems, conventional bottles and hydrogen generator. In order to check the pressure drop influence, it is need to monitor with each system along the proper time margin to let the bottles pressure decreases to the lower value admitted in the generator hydrogen feeding plant protocol. This time margin was fixed at 1 week after analyse different bottles recharging times.

**WORK PLAN: TEST PERFORMANCE**

On February 2007 a hydrogen generator will be installed to supply ultra high purity hydrogen to Group 3 at Compostilla power plant and the StableFlow™ continuous purge method was initiated.

Hydrogen gas purity was measured above 99% following the first full week of operation with the hydrogen generator and did not drop during the evaluation period.

**StableFlow™ Hydrogen Control System Installation**

In February 2007 Compostilla power plant will install a StableFlow™ Hydrogen Control System to automate the monitor and control process of the hydrogen system on generation Group 3. The StableFlow™ Hydrogen Control System will be initially operated for at least two weeks in monitor mode only and the plant reverted back to their “batch” hydrogen feed process to gather some baseline data. The StableFlow™ Hydrogen Control System will then take full control over the monitoring and control function of the hydrogen system. We expect the system to quickly make initial improvements to the purity and control the purge rate to optimize the hydrogen usage.

The chart pictured below is an example that illustrates the effect the hydrogen “batch”

feed process has on pressure stability, but also illustrates that hydrogen gas purity is also affected by the periodic pressure decay and re-pressurization cycles. Hydrogen gas purity will drop as the pressure in the generator decreases and immediately responds positively as “new” gas is introduced into the casing to re-pressurize.

As this trend continues the decrease in purity also continues to accumulate and will never fully recover until a significant purge of gas from the generator takes place under this process scenario. This cumulative negative effect on hydrogen casing purity takes a few days or a few weeks to get to the point where a purge needs to take place to correct the problem. The StableFlow™ Hydrogen Control System automatically and continuously maintains the casing purity above OEM specified levels.

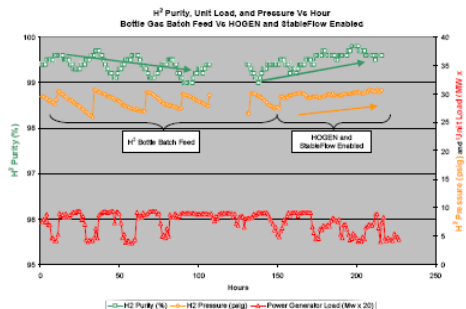

Figure2- Pressure stability vs. hydrogen purity

Implementing onsite hydrogen generation has also increased plant safety by reducing the amount of stored hydrogen on the plant premises. Onsite hydrogen generation will allow the plant to feed makeup hydrogen to the electric generators without the concern of a major hydrogen leak creating a hazardous environment. The ability of an onsite hydrogen generator to produce hydrogen with very little stored inventory requirements and the inherent ability to limit capacity makes it the safest form of hydrogen supply for generator cooling applications.

## CONCLUSIONS

The purpose of the project is to assess the affect hydrogen purity and pressure stability has on the operating efficiency and capacity of the electrical generating assets of Endesa's Compostilla Power Plant. The results achieved at Compostilla will be used to estimate the positive environmental impact to the EU.

The implementation of an onsite hydrogen generator will also be assessed at Compostilla to quantify the operational improvements. Eliminating the need to have hundreds of cylinders on the premises, will dramatically reduce the labor needed to track and account for the inventory as well as eliminate the monthly rental charges on the majority of the existing inventory. The hydrogen generator will be located right at the point of use and does not need any operator interaction to provide the required gas output to the gas manifold.

The cost of delivered hydrogen is relatively expensive when compared to onsite generation. Delivered gas prices fluctuate with the volatility associated with the supply, transportation, and increased security concerns over bulk hydrogen.

Onsite generation, especially when employed at a power plant, offers the plant operator a fixed cost of hydrogen supply. An electrolysis-based onsite hydrogen generator requires a small amount of demineralized water and electricity to operate. An onsite hydrogen generator sized for an average power plant requires less than 132 liters of water a day and 6.5kWh of electricity per normal cubic meter of hydrogen produced. As these feedstock components — water and electricity—are a surplus to the power plant, they enable the plant to effectively source its own hydrogen supply for a small fraction of what is paid for delivered gas.

## BIBLIOGRAPHY

/1/ Delgado Martín, A. Refrigeración de alternadores con hidrógeno producido mediante electrolizadores tipo PEM. Anales de mecánica y electricidad. Marzo- Abril 2005.

/2/ CADDET IEA-OECD Energy efficiency. Hydrogen purification system reduces generator power losses. April 1999.

/3/ Speranza, J. and Dusold, L. Improved generator performance utilizing onsite hydrogen generation and control. 4<sup>th</sup> EPRI Steam Turbine-Generator Technology Transfer Workshop.

/4/ IP/06/1434. Brussels, 19 October 2006. Saving 20% by 2020: European Commission unveils its Action Plan on Energy Efficiency.

## Authors:

Speranza, John<sup>1</sup>; Burgos Rodríguez, Silvia<sup>2</sup>; Ballesteros Aparicio, Juan Carlos<sup>3</sup>; De la Varga de la Cruz, Jesús<sup>4</sup>; Fontela Martínez, Pablo<sup>5</sup>; Francisco Sierra, Jose<sup>6</sup>; and Melusky, Robert<sup>7</sup>

<sup>1</sup> Vice President, Hydrogen Product Sales, Proton Energy Systems, 10 Technology Dr. Wallingford, CT, USA.

<sup>2</sup> Ph.D., M.Sc., Mining Engineer, R&D Unit, ENDESA Generación, Ribera del Loira 60, 28042 Madrid, Spain.

<sup>3</sup> Ph.D., M.Sc., Mining Engineer, Head of the R&D Unit, ENDESA Generación, Ribera del Loira 60, 28042 Madrid, Spain.

<sup>4</sup> M.Sc. Electrical Engineer, Generation Unit, ENDESA Generación, Ribera del Loira 60, 28042 Madrid, Spain.

<sup>5</sup> M.Sc. Industrial Engineer, Area Manager of the R&D Division, BESEL S.A., Leganés Tecnológico Parque Científico, Avda. del Mar Mediterráneo 22, 28918 Leganés Madrid, Spain.

<sup>6</sup> Research and Development Director, BESEL S.A., Leganés Tecnológico Parque Científico, Avda. del Mar Mediterráneo 22, 28918 Leganés Madrid, Spain.

<sup>7</sup> Manager, International Sales, Proton Energy Systems, 10 Technology Dr. Wallingford, CT, USA.